

ITEM	PART NO.	DESCRIPTION	QTY
1	7106295	FRAME BASE, SERVICE ASSEMBLY	1
2	7105877	HANDLE, SVC ASSY PS3228 REAR	1
† 2.1		HANDLE, REAR 18GA. 11.75" C-C BLACK	1
† 2.2		PLATE, DASHBOARD SILVER W/LABEL	1
† 2.3		NOZZLE HOLDER, 5PC RUBBER	1
† 2.4		SCREW, TORX PANHEAD 1/4"-20 x 3/4"	4
3	7106603	ENGINE, SVC ASSY HONDA GX200	1
4	7101506	KEY, SHAFT 3/16 X 3/16 X 1-1/2	1
¶ 5	7106572	PUMP, SVC ASSY KIT	1
5.1	530002	PUMP, 3200PSI @ 2.5GPM C30 SERIES	1
† 5.2		CAP, UNLOADER COVER 1 1/2" x 5/8" BLACK	1
† 5.3		BOLT 5/16"-24 x 1" HHCS GR5	4
† 5.4		WASHER, SPLIT-LOCK 5/16" RUST RESISTANT	4
6	7105013	WHEEL, SERVICE KIT	1
† 6.1		POWER WASHER WHEEL, 4" x 10" BLK W/ 5/8" BRG	2
† 6.2		WASHER, 5/8" FLAT	2
† 6.3		CLIP, E-TYPE 0.625" x 0.042"	2
7	7103292	KIT, 5/8" TALL FOOT	2
† 7.1		FOOT, RUBBER 1.5"ODx.625"-5/16 INSERT	1
† 7.2		SCREW, TORX PANHEAD 1/4"-20 x 3/4"	1
8	7103750	MOUNTING KIT, ENGINE	1
† 8.1		BOLT, FLANGE 5/16"-18 x 1 3/4" HHFB	4
† 8.2		NUT, WHIZ 5/16"-18	4
9	7105474	HARDWARE KIT, PUMP MOUNTING	1
† 9.1		BOLT 5/16"-24 x 1" HHCS GR5	4
† 9.2		WASHER, SPLIT-LOCK 5/16" RUST RESISTANT	4
10	7104570	HARDWARE KIT, HANDLE MOUNTING	2
† 10.1		BOLT, SADDLE 5/16"-18 x 2"	1
† 10.2		KNOB, HANDLE 5/16-18	1
11	7103743	NOZZLE SET, 3.0 5PC 1/4" QC-M	1
12	7105186	HANDLE GRIP, SILVER	1
13	7108124	TRIGGER SPRAY GUN 4500PSI @ 6.6GPM M22(M) x M22(F)	1
14	7103550	LANCE, 16" W/ 1/4" QC-F x M22(M)	1
15	7103726	HOSE, 9/32" x 25' x 3400PSI M22(M) x M22(F) PLATINUM	1
16	7102207	SOAP HOSE AND FILTER KIT	1
* 17	7102045	TOOL, NOZZLE CLEANING, UNIVERSAL	1
* 18	7104986	MANUAL, PS3228 MODEL SPECIFIC OPERATOR'S	1
* 19	7104985	BOX, PS3228 MODEL SPECIFIC SHIPPING	1

* NOT SHOWN

† NOT SOLD SEPERATELY

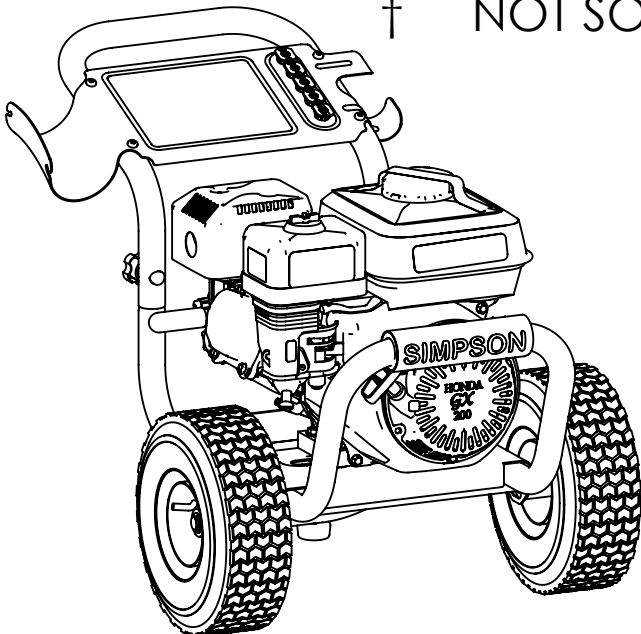

PUMP INFORMATION TABLE			
MACHINE SERIAL NO.	PUMP TYPE	PUMP PART NO.	PUMP KIT NO.
143341 TO 390473	9.6GA12	7105902	7104984
394597 TO PRESENT	9.6GA12	530002	7106572

ONLY THE LATEST VERSION OF THE PUMP IS AVAILABLE FOR REPLACEMENT

	NAME	DATE
DRAWN	TV	5/12/2014
CHECKED	M.G.	5/12/2014
ENG APPR.	S.A.C.	5/13/2014
MFG APPR.	J.C.P.	4/16/2013
Q.A. APPR.	J.C.	5/12/2014
SERVICE APPR.	D.H.	4/16/2013

PROPRIETARY AND CONFIDENTIAL
 THE INFORMATION CONTAINED IN THIS DRAWING IS THE SOLE PROPERTY OF FNA-GROUP. ANY REPRODUCTION IN PART OR AS A WHOLE WITHOUT THE WRITTEN PERMISSION OF FNA-GROUP IS PROHIBITED.

FNA-GROUP		
1265 INDUSTRIAL STREET, DECATUR, AR 72722		
TITLE:		
PS3228 & PS3228-S 3200PSI @ 2.8GPM SIMPSON		
SIZE	DWG. NO.	REV.
A	60585-S & 60629-S	C
SCALE: N/A	ECN# DC14-0114	SHEET 1 OF 9

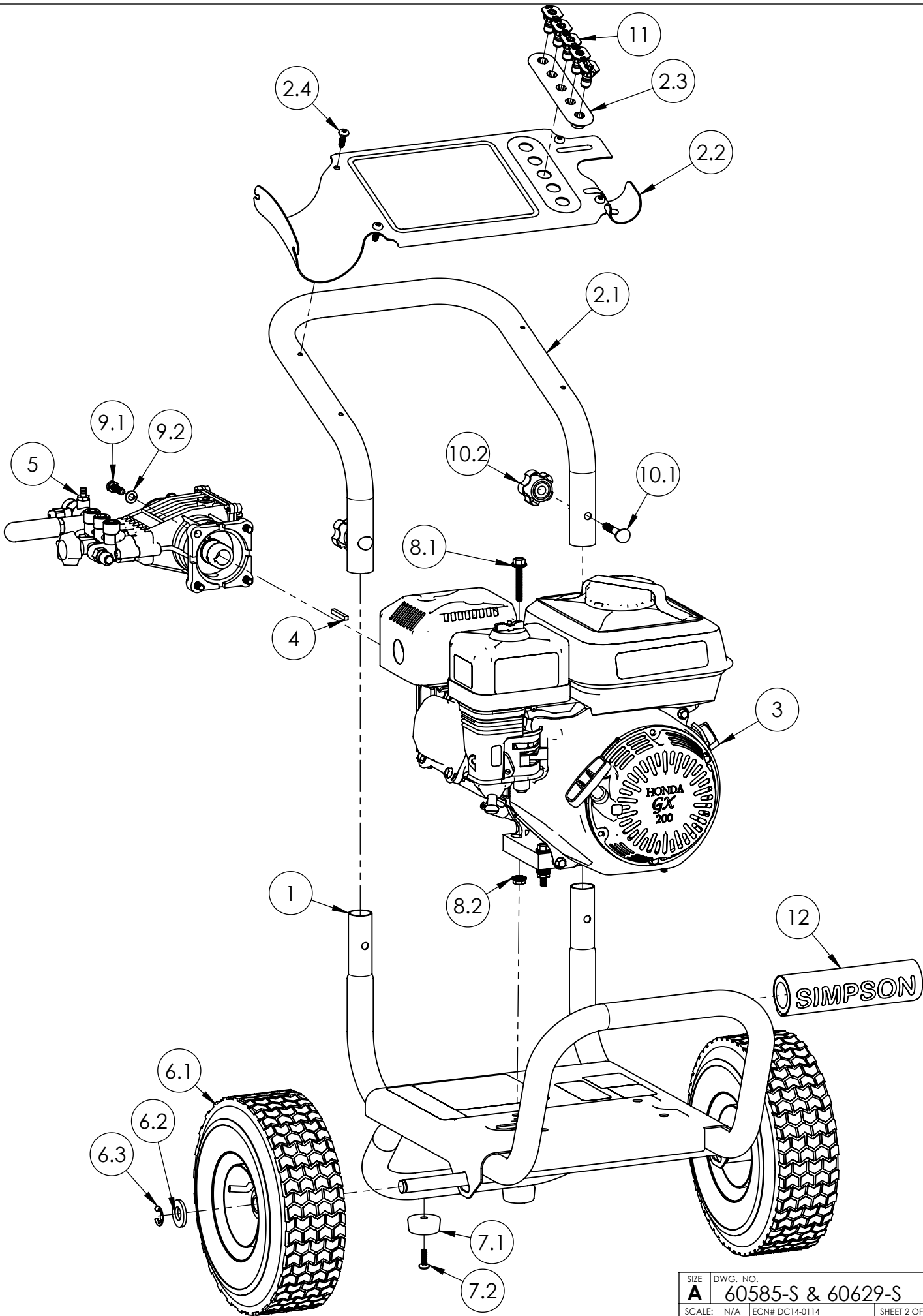

SIZE	DWG. NO.	REV.
A	60585-S & 60629-S	C
SCALE: N/A	ECN# DC14-0114	SHEET 2 OF 9

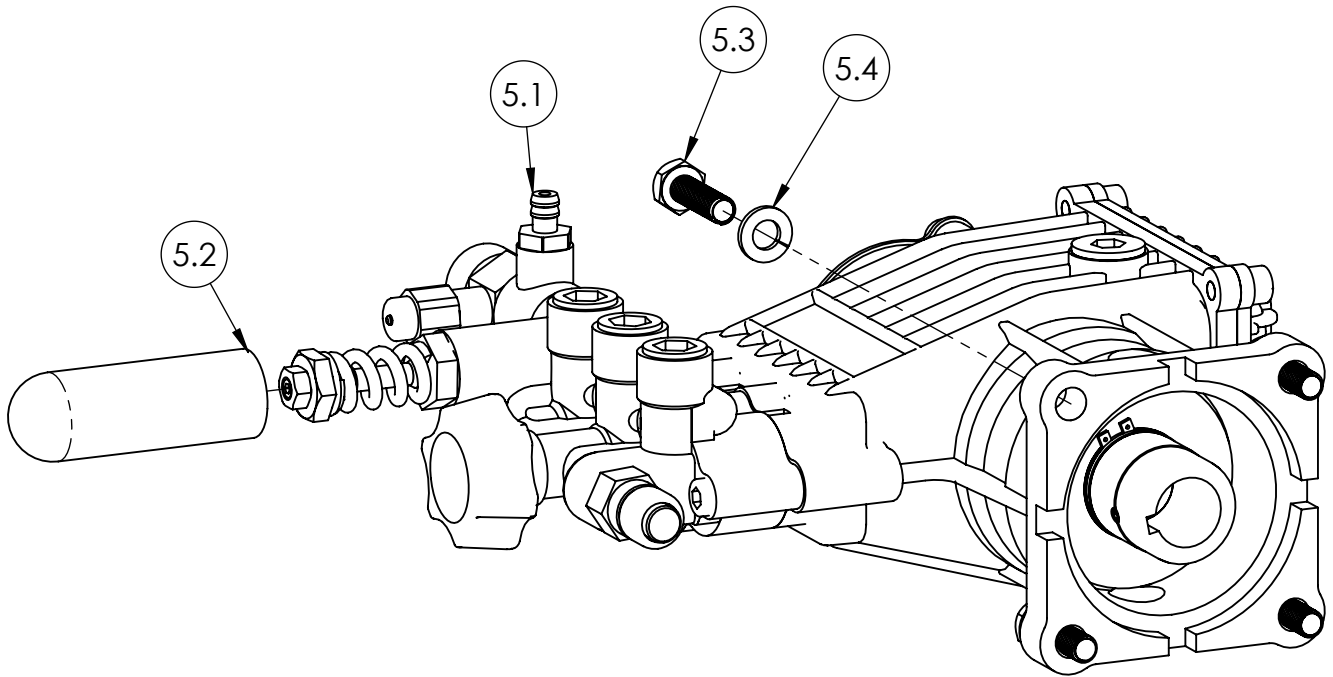

PUMP, SVC ASSY 3200PSI @ 2.5GPM
PART NO. 7106572

ITEM	PART NO.	DESCRIPTION	QTY
5.1	530002	PUMP,3200PSI @ 2.5GPM C30 SERIES	1
5.2		CAP, UNLOADER COVER 1 1/2" x 5/8" BLACK	1
5.3		BOLT 5/16"-24 x 1" HHCS GR5	4
5.4		WASHER, SPLIT-LOCK 5/16" RUST RESISTANT	4
* 4	7101506	KEY, 3/16" x 3/16" x 1 1/2" SHAFT	1

* NOT SHOWN

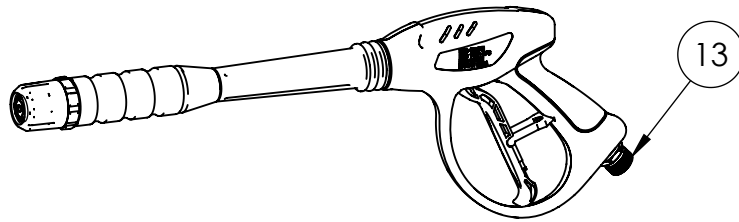

TRIGGER SPRAY GUN 3600PSI @ 6.6GPM M22(M) x M22(F)
PART NO. 7106275

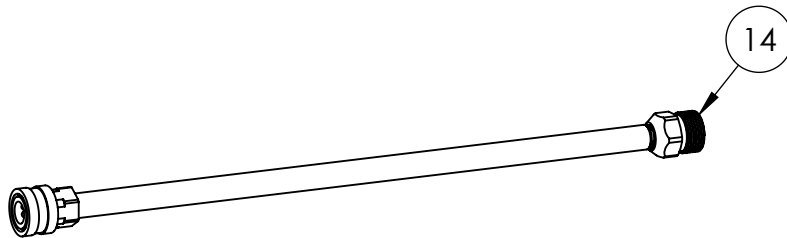

LANCE, 16" W/ 1/4" QC-F x M22(M)
PART NO. 7103550

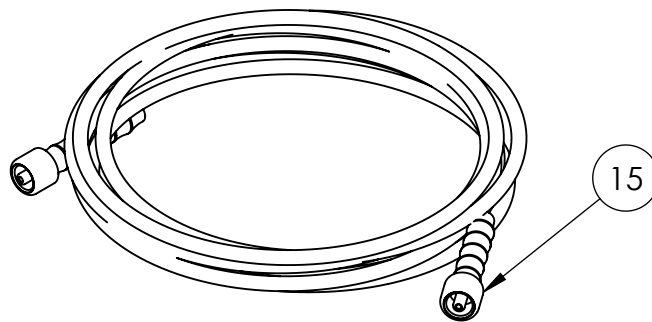

HOSE, 9/32" x 25' x 3400PSI M22(M) x M22(F) PLATINUM
PART NO. 7103726

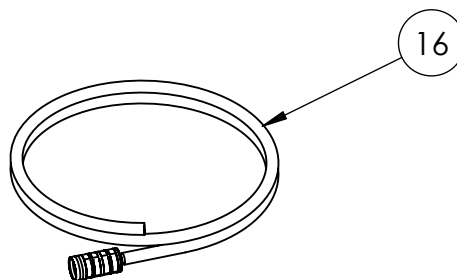

KIT, SOAP HOSE & FILTER
PART NO. 7102207

PUMPS COVERED BY THIS DOCUMENT	
PART NO.	MODEL
530001	8.7GA12
530002	9.6GA12

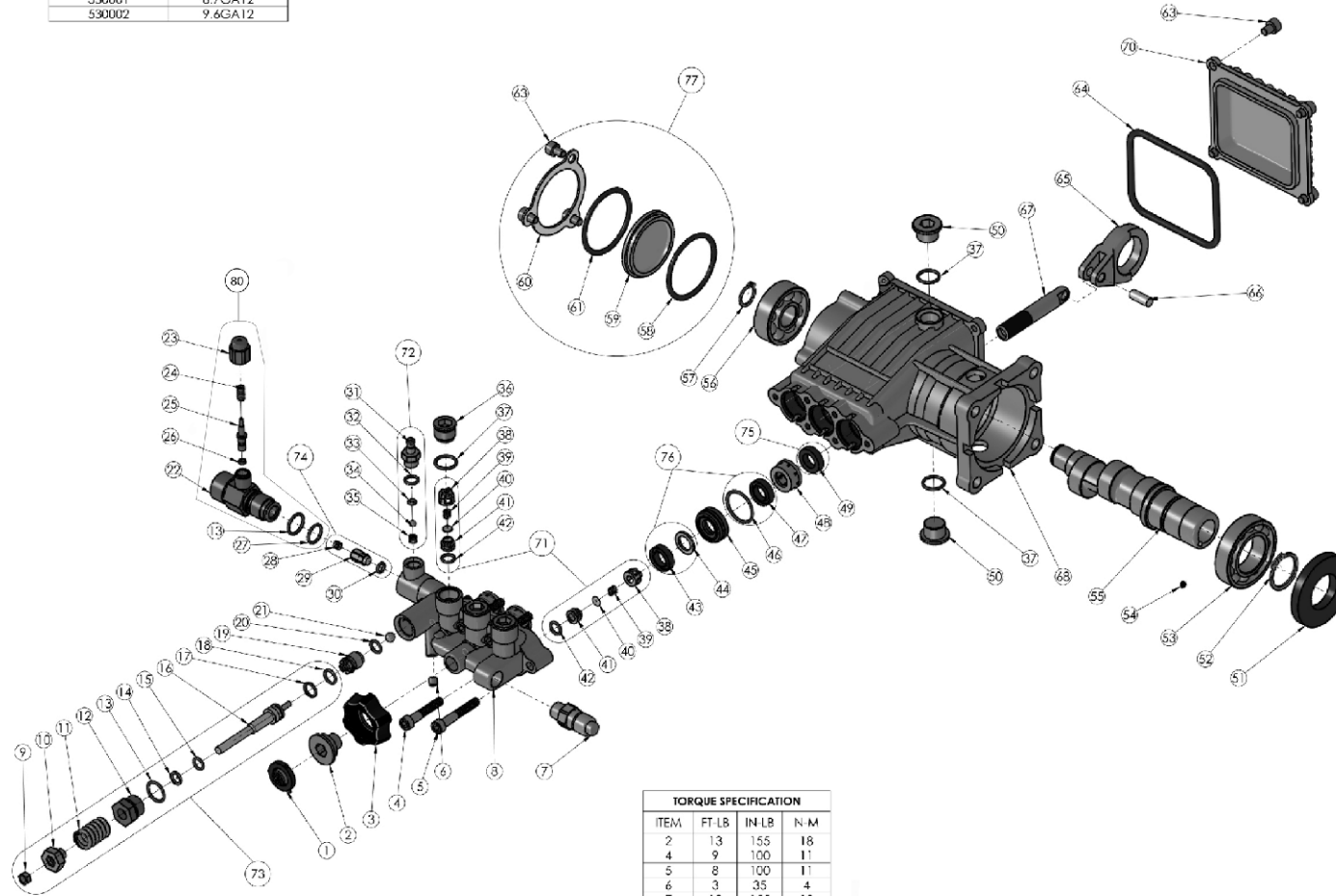

TORQUE SPECIFICATION			
ITEM	FT-LB	IN-LB	N-M
2	13	155	18
4	9	100	11
5	8	100	11
6	3	35	4
7	13	155	18
12	13	155	18
22	13	155	18
23	13	155	18
31	9	110	13
36	13	155	18
50	13	155	18
63	7	80	9

ITEM	PART NO.	DESCRIPTION	QTY
1	7000123	SCREEN, WATER INLET	1
2	7105704	CONNECTOR, WATER INLET	1
3	7105705	NUT, HAND TIGHT	1
4	7000325	SCREW	3
5	7104692	SCREW	3
6	7005061	SCREW, SET	1
7	7101359	VALVE, THERMAL RELIEF	1
8	7105706	MANIFOLD	1
9	N/A	NUT, UNLOADER JAM	1
10	N/A	NUT, UNLOADER ADJUSTMENT	1
11	N/A	SPRING, UNLOADER	1
12	N/A	GUIDE BUSHING UNLOADER	1
13	7105707	O-RING	2
14	N/A	BACK-UP RING, UNLOADER VALVE	1
15	N/A	O-RING	1
16	N/A	STEM, UNLOADER	1
17	N/A	O-RING	1
18	N/A	BACK-UP RING, SPLIT	1
19	7105708	VALVE SEAT	1
20	7105709	O-RING	1
21	7105710	BALL, UNLOADER VALVE	1
22	7105711	BODY, SOAP INJECTOR	1
23	7105712	CAP, BOOST VALVE	1
24	7105713	SPRING, BOOST VALVE	1
25	7105714	VALVE, PRESSURE BOOST	1
26	7105715	O-RING	1
27	7105716	O-RING	1
28	N/A	SPRING, CHECK VALVE	1
29	N/A	CHECK VALVE	1
30	N/A	O-RING	1
31	N/A	FITTING, SOAP INJECTION	1
32	N/A	O-RING	1
33	N/A	O-RING	1
34	N/A	BALL, SOAP VALVE	1
35	N/A	SPRING, SOAP VALVE	1
36	7105717	PLUG MANIFOLD	3
37	7105718	O-RING	5
38	N/A	CAGE, VALVE	6
39	N/A	SPRING, VALVE	6
40	N/A	DISK, VALVE	6

ITEM	PART NO.	DESCRIPTION	QTY
41	N/A	SEAT, VALVE	6
42	N/A	O-RING	6
43	N/A	SEAL HIGH PRESSURE	3
44	N/A	RING, ANTI-EXT	3
45	7105719	RETAINER	3
46	N/A	O-RING	3
47	N/A	SEAL, LOW PRESSURE	3
48	7105720	RETAINER, SEAL	3
49	N/A	SEAL, OIL	3
50	7105721	PLUG, CRANKCASE	2
51	7105722	SEAL, OIL	1
52	7105723	RING, RETAINING	1
53	7105724	BEARING, CRANKSHAFT	1
54	7103426	SCREW	1
55	-	CRANKSHAFTS	-
-	7105725	CRANKSHAFT 8.7GA12	1
-	7105726	CRANKSHAFT, 9.6GA12	1
56	7105727	BEARING, CRANKSHAFT	1
57	7105729	RING, RETAINING	1
58	N/A	O-RING	1
59	7105918	SIGHT GLASS	1
60	7105919	CRANKSHAFT, SIDE COVER	1
61	N/A	RING, RETAINING	1
63	N/A	SCREW	7
64	7105920	GASKET	1
65	7105730	CONNECTING ROD	3
66	7105731	PIN, CONNECTING ROD	3
67	7105732	PISTON, CERAMIC COATED	3
68	7105733	CRANKCASE, PUMP	1
70	7105922	CRANKCASE, END COVER	1

ITEM	PART NO.	DESCRIPTION	QTY
71	7104223	VALVE KIT	6
72	7104228	SOAP INJECTOR KIT	1
73	7105739	UNLOADER KIT	1
74	7105740	UNLOADER CHECK VALVE KIT	1
75	7105741	OIL SEAL KIT	1
76	7105742	HIGH AND LOW PRESSURE SEAL KIT	1
77	7105921	CRANKCASE SIDE COVER KIT	1
78	7105745	MANIFOLD KIT	1
79	-	CRANKCASE KIT	-
	7105936	CRANKCASE KIT, 8.7GA12	1
	7105937	CRANKCASE KIT, 9.6GA12	1
80	7106264	OUTLET FITTING KIT	1

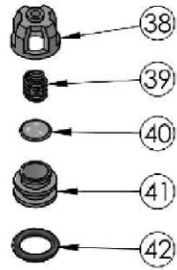

7104223
ITEM 71 VALVE KIT

ITEM	QTY	DESCRIPTION
38	6	CAGE, VALVE
39	6	SPRING, VALVE
40	6	DISK, VALVE
41	6	SEAT, VALVE
42	6	O-RING

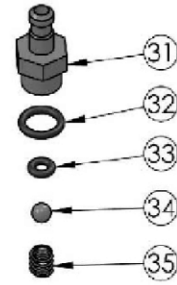

7104228
ITEM 72 SOAP INJECTOR KIT

ITEM	QTY	DESCRIPTION
31	1	FITTING, SOAP INJECTION
32	1	O-RING
33	1	O-RING
34	1	BALL, 3/16" SOAP VALVE
35	1	SPRING, SOAP VALVE

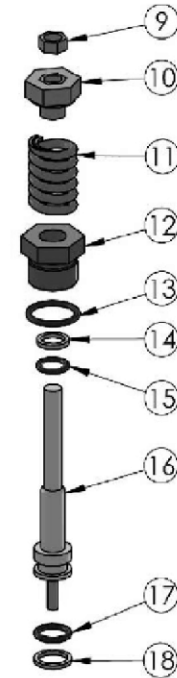

7105739
ITEM 73 UNLOADER KIT

ITEM	QTY	DESCRIPTION
9	1	NUT, UNLOADER .AM
10	1	NUT, UNLOADER ADJUSTMENT
11	1	SPRING, UNLOADER
12	1	GUIDE BUSHING, UNLOADER
13	1	O-RING
14	1	BACK-UP RING, UNLOADER VALVE
15	1	O-RING
16	1	STEM, UNLOADER
17	1	O-RING
18	1	BACK-UP RING, SPLIT

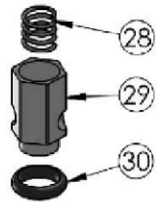

7105740
ITEM 74 UNLOADER CHECK VALVE KIT

ITEM	QTY	DESCRIPTION
28	1	SPRING, CHECK VALVE
29	1	CHECK VALVE
30	1	O-RING



7105741
ITEM 75 OIL SEAL KIT

ITEM	QTY	DESCRIPTION
49	3	SEAL, OIL

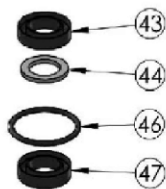

7105742
ITEM 76 HIGH AND LOW PRESSURE SEAL KIT

ITEM	QTY	DESCRIPTION
43	3	SEAL, HIGH PRESSURE
44	3	RING, ANTI-EXT
46	3	O-RING
47	3	SEAL, LOW PRESSURE

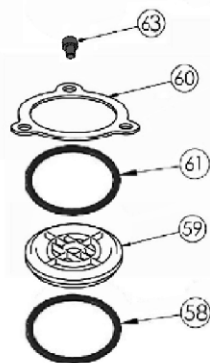

ITEM 77 CRANKCASE END COVER KIT

PART NO.	DESCRIPTION
7105921	CRANKCASE SIDE COVER KIT

ITEM	QTY	DESCRIPTION
58	1	O-RING
59	1	SIGHT GLASS
61	1	O-RING (Flat)
60	1	CRANKCASE, SIDE COVER
63	3	SCREW

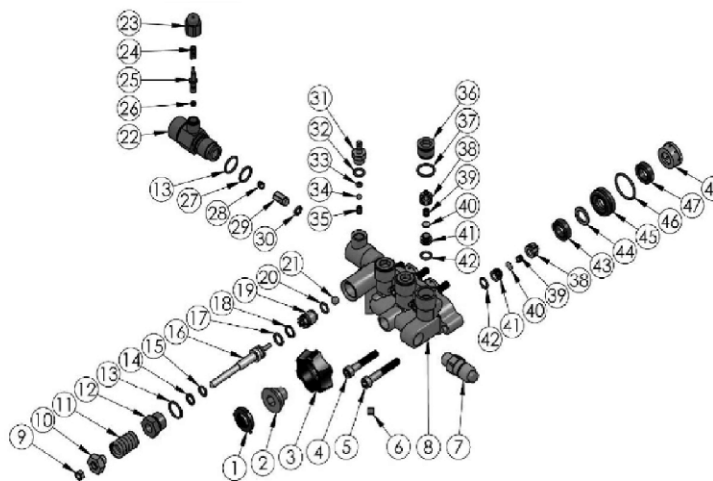

7105745
ITEM 78 MANIFOLD KIT

ITEM	QTY	DESCRIPTION
1	1	SCREEN, WATER INLET
2	1	CONNECTOR, WATER INLET
3	1	NUT, HAND TIGHT
4	3	SCREW
5	3	SCREW
6	1	SCR.W, SET
7	1	VALVE, THERMAL RELIEF
8	1	MANIFOLD
9	1	NUT, UNLOADER JAM
10	1	NUT, UNLOADER ADJUSTMENT
11	1	SPRING, UNLOADER
12	1	GUIDE BUSHING, UNLOADER
13	2	O-RING
14	1	BACK-UP RING, UNLOADER VALVE
15	1	O-RING
16	1	STEM, UNLOADER
17	1	O-RING
18	1	BACK-UP RING, SPLIT
19	1	VALVE SEAT
20	1	O-RING
21	1	BALL, UNLOADER VALVE
22	1	BODY, SOAP INJECTOR
23	1	CAP, BOOST VALVE
24	1	SPRING, BOOST VALVE

ITEM	QTY	DESCRIPTION
25	1	VALVE, PRESSURE BOOST
26	1	O-RING
27	1	O-RING
28	1	SPRING, CHECK VALVE
29	1	CHECK VALVE
30	1	O-RING
31	1	FITTING, SOAP INJECTION
32	1	O-RING
33	1	O-RING
34	1	BALL, 3/16" SOAP VALVE
35	1	SPRING, SOAP VALVE
36	3	PLUG, MANIFOLD
37	3	O-RING
38	6	CAGE, VALVE
39	6	SPRING, VALVE
40	6	O-RING, VALVE
41	6	SEAT, VALVE
42	6	O-RING
43	3	SEAL, HIGH PRESSURE
44	3	RING, ANTI-EXT
45	3	RETAINER
46	3	O-RING
47	3	SEAL, LOW PRESSURE
48	3	RETAINER, SEAL

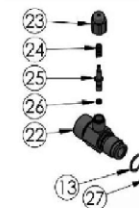

7106264

ITEM 80 OUTLET FITTING KIT

ITEM	QTY	DESCRIPTION
23	1	CAP, BOOST VALVE
24	1	SPRING, POWER BOOST VALVE
25	1	VALVE, PRESSURE BOOST
26	1	O-RING
22	1	BODY, SOAP INJECTOR
13	1	O-RING
27	1	O-RING

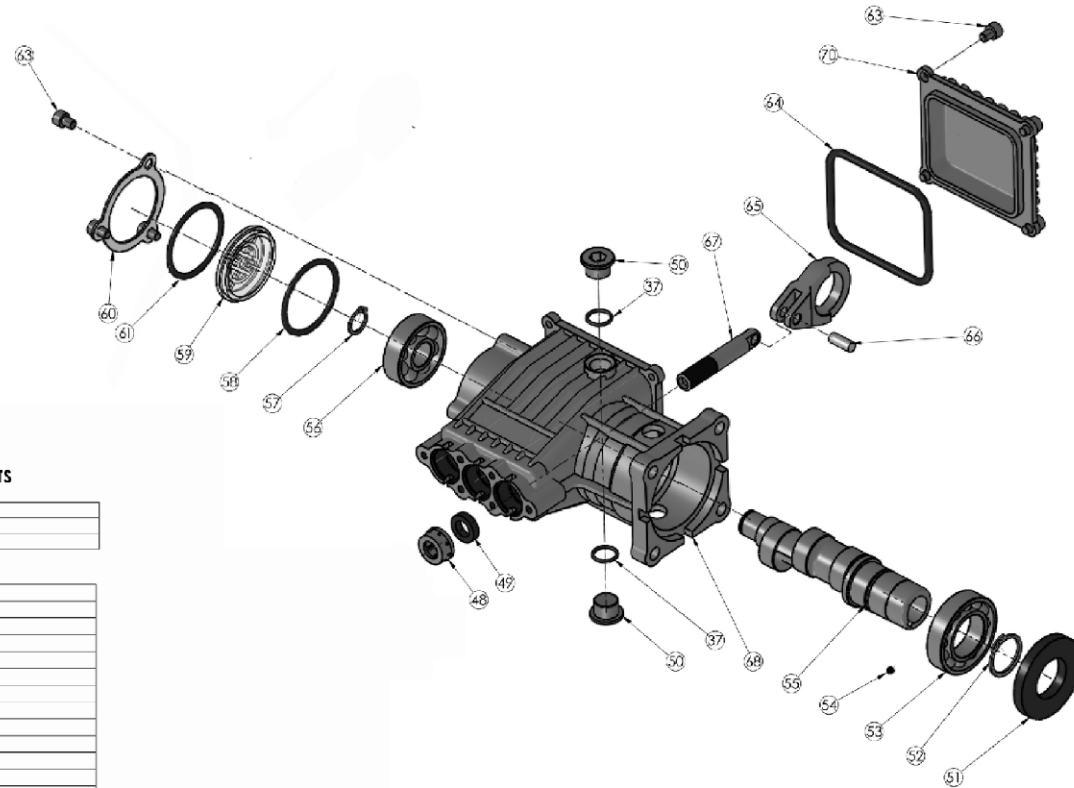

ITEM 79 CRANKCASE KITS

PART NO.	DESCRIPTION
7105936	CRANKCASE KIT 8.7GA12
7105937	CRANKCASE KIT 9.6GA12

ITEM	QTY	DESCRIPTION
37	1	O RING
48	3	RETAINER, SEAL
49	3	SEAL, OIL
50	2	PLUG, CRANKCASE
51	1	SEAL, OIL
52	1	RING, RETAINING
53	1	BEARING, CRANKCASE
54	1	SCREW
55	-	CRANKSHAFT
	1	CRANKSHAFT 8.7GSA12
	1	CRANKSHAFT 9.6GA12
56	1	BEARING, CRANKSHAFT
57	1	RING, RETAINING
58	1	O-RING
59	1	SIGHT GLASS
60	1	CRANKCASE SIDE COVER
61	1	RETAINING RING
63	7	SCREW
64	1	GASKET
65	3	CONNECTING ROD
66	3	PIN, CONNECTING ROD
67	3	PISTON, CERAMIC COATED
68	1	CRANKCASE, HOUSING
70	1	CRANKCASE, END COVER